

POWER & EFFICIENCY

INPUT POWER OPTIONS	AC 1PH 200-240V 50/60HZ		AC 3PH 200-240V 50/60HZ
CURRENT AT MAX SPEED (Amp)	2.0 A		1.2 A
POWER (hp)	5/8 HP		
MAXIMUM SPEED (RPM)	156 RPM		
MAX EFFECTED AREA	52 ft (15.84M) 2704 sqft (251.20M2)		

DIMENSIONS & WEIGHT

FAN DIAMETER	8 ft (2.4m)
FAN WEIGHT	104lbs (47.3 kg)

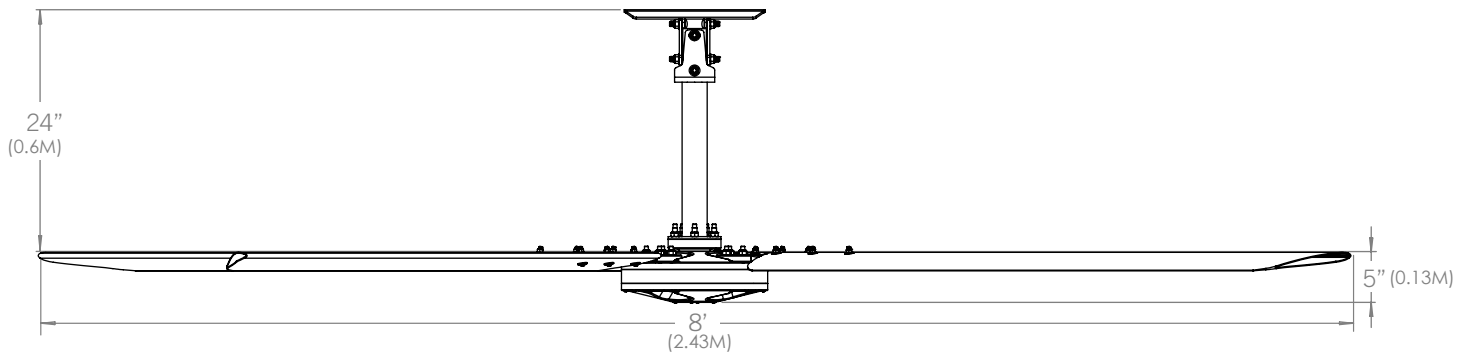

MOUNTING & SAFETY

DOWNROD	2' (0.18M) Rigid Mount Downrod
SAFETY FEATURES	Fan Retention System Fire Relay

IN THE BOX

INCLUDED	Rigid Mount with Pre-Wired Downrod Control Panel Install Manual Airfoils Standard Control Mounting Hardware Kit Communication Kit
OPTIONAL	Additional Colors 3' (0.91M) and 4' (1.21M) Rigid Mount Downrod Additional Control Cable Lengths

WARRANTY & CERTIFICATIONS

CERTIFICATIONS	ETL/Intertek-certified to ANSI/UL 507 and CSA C22.2 No. 113 in North America INTERNATIONAL IEC 61800-3 AND CE
WARRANTY ¹	Limited Lifetime on Airfoils 2-Year Warranty

¹See complete warranty for details.