

## POWER & EFFICIENCY

INPUT POWER OPTIONS	AC 1PH 200-240V 50/60HZ		AC 3PH 200-240V 50/60HZ
CURRENT AT MAX SPEED (Amp)	3.6 A		1.9 A
POWER (hp)	5/8 HP		
MAXIMUM SPEED (RPM)	107 RPM		
MAX EFFECTED AREA	67 ft (20.42M)   4,489 sqft (417.04M2)		

## DIMENSIONS & WEIGHT

FAN DIAMETER	12 ft (3.7m)
FAN WEIGHT	117lbs (53.2 kg)

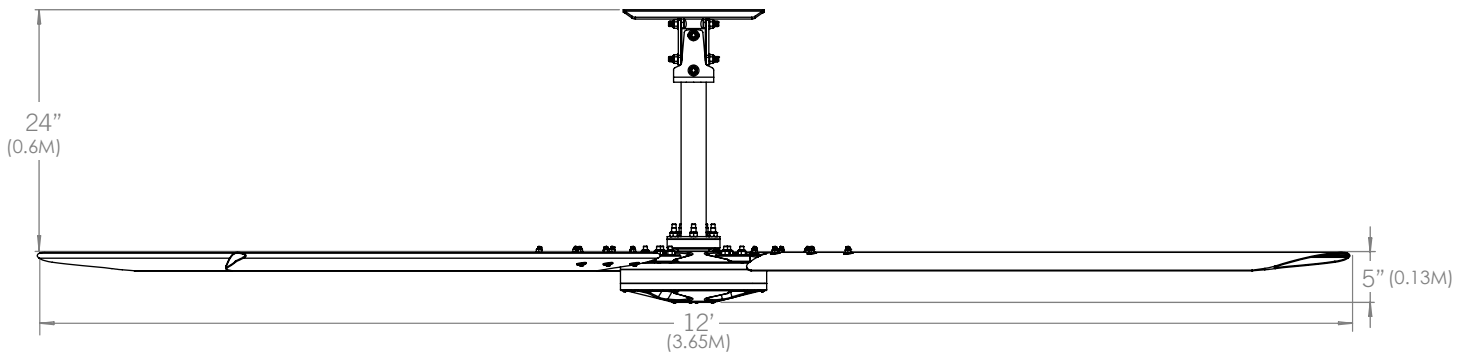

## MOUNTING & SAFETY

DOWNROD	2' (0.18M) Rigid Mount Downrod
SAFETY FEATURES	Fan Retention System   Fire Relay

## IN THE BOX

INCLUDED	Rigid Mount with Pre-Wired Downrod   Control Panel   Install Manual   Airfoils Standard Control   Mounting Hardware Kit   Communication Kit
OPTIONAL	Additional Colors   3' (0.91M) and 4' (1.21M) Rigid Mount Downrod   Additional Control Cable Lengths

## WARRANTY & CERTIFICATIONS

CERTIFICATIONS	ETL/Intertek-certified to ANSI/UL 507 and CSA C22.2 No. 113 in North America   INTERNATIONAL IEC 61800-3 AND CE
WARRANTY <sup>1</sup>	Limited Lifetime on Airfoils   2-Year Warranty

<sup>1</sup>See complete warranty for details.